

INSTALLATION INSTRUCTIONS – 004E

rev. 2 del 31/03/2011

HEATING CABLE SPCB – ASSEMBLY INSTRUCTIONS FOR END SEAL AND POWER CONNECTION

The following installation procedures are suggested guidelines for the installation of termination connection systems. They are not intended to preclude the use of other methods and good engineering or field construction practices. Installation must comply with our requirements and any other applicable national and local laws.

TOOLS REQUIRED:

3 Shrink Sleeve D.6/2 L= 25mm SCPC3; 1 Shrink Sleeve D.6/2 L= 50mm SCPC4

Wire cutter; Trimming knife; Hot air gun

END SEAL

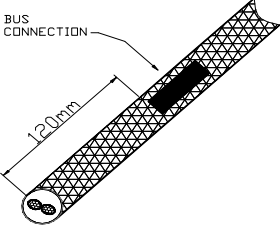
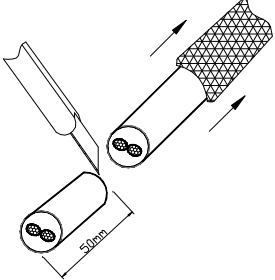
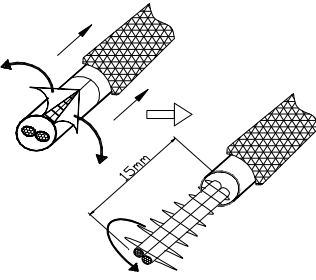
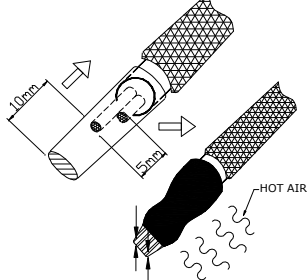
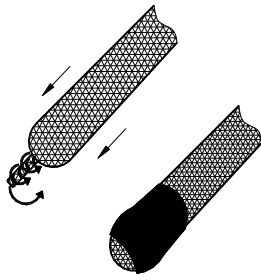
1		2		3		4		5	
	<p>Cut the heating cable at 120mm from the bus connection (black point on the surface of the cable).</p>		<p>Push back metallic braid. Cut 40mm of heater.</p>		<p>Cut and remove the insulation jacket and the heating wire. Push any remaining heating element wire under the insulation jacket.</p>		<p>Stagger cut one of the bus wires (5mm). Position the heat shrink sleeve SCPC4 as shown and shrink by hot air gun. Squeeze the sleeve end to stick and seal.</p>		<p>Pull back braid to cover the sleeve SCPC3. Twist the braid end and bend it. Position one heat-shrink sleeve SCPC1 as shown and shrink.</p>

POWER CONNECTION

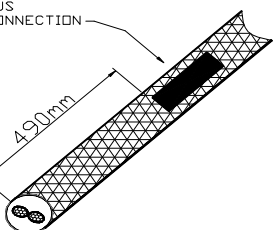
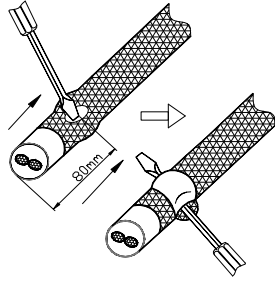
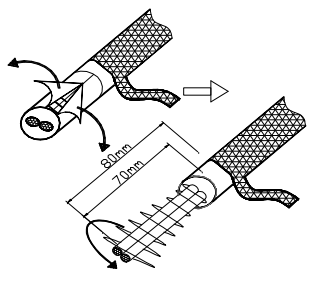
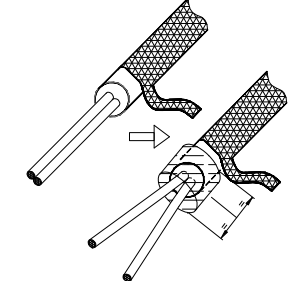
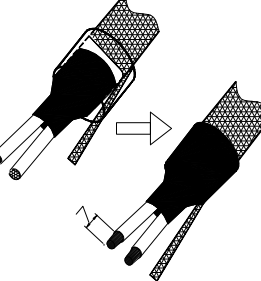
1		2		3		4		5	
	<p>Cut the heating cable at least 490mm from the first bus connection (black point on the surface of the cable).</p>		<p>Make an opening at 80mm. Push back braid to increase its diameter and loosen. Remove the heater</p>		<p>Cut and remove the insulation jacket and the heating wire. Push any remaining heating element wire under the insulation jacket.</p>		<p>Be sure bus wire insulation must not be damaged. Position one heat shrink sleeve SCPC3 as shown and shrink by hot air gun.</p>		<p>Position one heat shrink sleeve SCPC3 as show and shrink by hot air gun. Remove for 7mm insulation jacket on conductors.</p>

WARNINGS:

- * Due to the risk of electrical shock, arcing and fire caused by product damage or improper usage, installation or maintenance, a group-fault protection device is required.
- * Keep ends of heating cable and kit components dry before and during installation.